

# THERMOCOUPLES / THERMOMETER

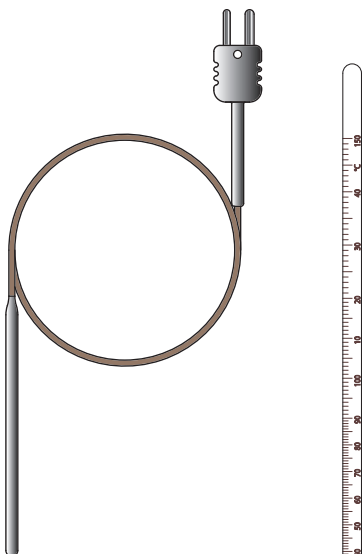

**CG-15001  
CG-15018**



**CG-3501**

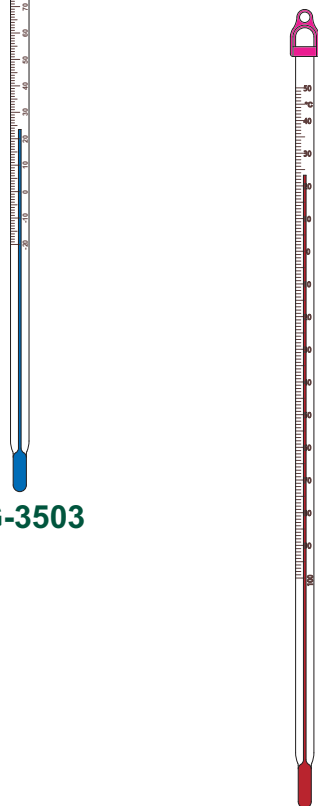

**CG-3503**

**CG-3503-L**

## CG-15001 / 15018 THERMOCOUPLE, TYPE "J", LIQUID IMMERSION

Type "J" thermocouple (black) for use with oil baths or other liquid immersion applications. Thermocouple is supplied with a mini plug and a insulated and stainless steel overbraided cord. Thermocouples can be used to 370°C with the exception of the Code -02 which is good up to 260°C.

### Non-Coated:

Part Number	Diameter (in)	Length (in)	Cord Length (in)
CG-15001-25	1/8	6	36
CG-15018-01	1/8	6	48

### Teflon Coated:

Part Number	Diameter (in)	Length (in)	Cord Length (in)
CG-15018-02	1/8	6	48

## CG-3501 THERMOMETER, NON-MERCURY, TOTAL IMMERSION

Thermometer is mineral spirit filled to eliminate workplace and environmental hazards associated with mercury. All ranges have 1° subdivisions. Thermometer has a white back and a 6 to 7mm outer diameter.

Part Number	Range (°C)	Overall Length (mm)
CG-3501-01	-20 to 110	305
CG-3501-02	-20 to 150	305

## CG-3503 THERMOMETER, NON-MERCURY, PARTIAL IMMERSION

Thermometer is mineral spirit filled to eliminate workplace and environmental hazards associated with mercury. All ranges have 1° subdivisions. Thermometer has a white back and a 6 to 7mm outer diameter, and is calibrated for 76mm (3") immersion.

Part Number	Range (°C)	Overall Length (mm)
CG-3503-10	-20 to 110	305
CG-3503-11	-20 to 150	305
CG-3503-12	-10 to 250	380

## CG-3503-L THERMOMETER, NON-MERCURY, PARTIAL OR TOTAL IMMERSION, LOW TEMPERATURE

Thermometer is mineral spirit filled to eliminate workplace and environmental hazards associated with mercury. All ranges have 1° subdivisions. Thermometer has a white back and a 6 to 7mm outer diameter. Available in total or partial 76mm (3") immersion.

Part Number	Range (°C)	Immersion Type
CG-3503-L-20	-100 to 50	Total
CG-3503-L-21	-100 to 50	Partial

## CG-3505 THERMOMETER, NON-MERCURY, VARIABLE IMMERSION

Thermometer is mineral spirit filled to eliminate workplace and environmental hazards associated with mercury. All ranges have 1° subdivisions. Thermometer has a white back and a 6 to 7mm outer diameter. Constructed on two types of tubing sealed together below the scale where the stem portion is made of very fine bore glass to minimize correction factors at immersion depths other than the mid-point of the stem. The scale portion is made of wide bore glass to facilitate reading of the thermometer. Each thermometer is supplied with an instruction sheet and listing of correction factors. Can be used with any Chemglass threaded thermometer adapter.

Part Number	Range (° C)	Immersion Range (mm & in)	Overall Length (mm)
CG-3505-01	-10 to 250	76-178, (3-7)	510
CG-3505-02	-10 to 250	178-305, (7-12)	635

## CG-3506-N THERMOMETER, NON-MERCURY, 10/30 JOINT

Thermometer is mineral spirit filled to eliminate workplace and environmental hazards associated with mercury. All ranges have 1° subdivisions. Thermometer has a white back and a 6 to 7mm outer diameter with a standard taper 10/30 inner ground joint. Immersion is measured from the bottom of the joint to the bottom of the mercury bulb.

Part Number	Immersion (mm)	Range (° C)
CG-3506-N-01	25	-20 to 150
CG-3506-N-02	51	-20 to 150
CG-3506-N-03	76	-20 to 150
CG-3506-N-12	25	-10 to 250
CG-3506-N-13	51	-10 to 250
CG-3506-N-14	76	-10 to 250
CG-3506-N-15	100	-10 to 250
CG-3506-N-16	125	-10 to 250
CG-3506-N-17	152	-10 to 250

## CG-3507-N THERMOMETER, NON-MERCURY, 7/12 JOINT

Thermometer is mineral spirit filled to eliminate workplace and environmental hazards associated with mercury. All ranges have 2° subdivisions. Thermometer has a white back and a 6 to 7mm outer diameter with a standard taper 7/12 inner ground joint. Immersion is measured from the bottom of the joint to the bottom of the mercury bulb.

Part Number	Immersion (mm)	Range (° C)
CG-3507-N-01	20	0 to 150
CG-3507-N-02	20	0 to 300
CG-3507-N-03	40	0 to 150
CG-3507-N-04	40	0 to 300



CG-3505



CG-3506-N



CG-3507-N

# THERMOMETERS / TUBES

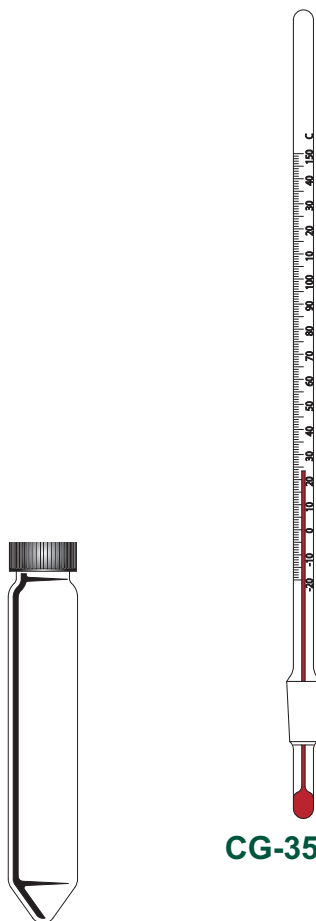

**CG-3508-N**

## CG-3508-N THERMOMETER, NON-MERCURY, 10/18 JOINT

Thermometer is mineral spirit filled to eliminate workplace and environmental hazards associated with mercury. All ranges have 1° subdivisions. Thermometer has a white back and a 6 to 7mm outer diameter with a standard taper 10/18 inner ground joint. Immersion is measured from the bottom of the joint to the bottom of the mercury bulb.

Part Number	Immersion (mm)	Range (°C)
CG-3508-N-01	25	-20 to 150
CG-3508-N-02	25	-10 to 250
CG-3508-N-03	51	-20 to 150
CG-3508-N-04	51	-10 to 250
CG-3508-N-06	76	-10 to 250

**CG-4013**

## CG-4013 TUBE, CENTRIFUGE, 50mL, UNGRADUATED

Centrifuge tube with a short, conical bottom and 24-415 GPI thread. Fits I.E.C. shield number 320. Supplied complete with a Poly-Seal® polypropylene lined phenolic screw cap.

Part Number	Capacity (mL)	GPI Thread Size	Approx OD x Length (mm)
CG-4013-01	50	24-415	28 x 155

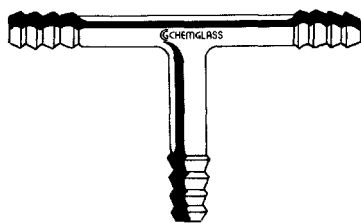

**CG-4022**

## CG-4022 TUBE, CONNECTING, T-SHAPE

T-shaped tube having serrated ends for connection of rubber, latex or Tygon® tubing.

Part Number	Tubing OD (mm)	Hose Connection
CG-4022-01	8.0	CG-300-01
CG-4022-02	10.0	CG-300-02
CG-4022-03	12.7	CG-300-03

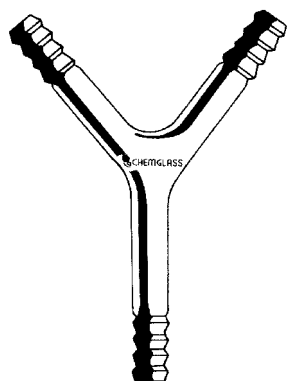

**CG-4023**

## CG-4023 TUBE, CONNECTING, Y-SHAPE

Y-shaped tube having serrated ends for connection of rubber, latex or Tygon® tubing.

Part Number	Tubing OD (mm)	Hose Connection
CG-4023-01	8.0	CG-300-01
CG-4023-02	10.0	CG-300-02
CG-4023-03	12.7	CG-300-03