

CG-2098 STOPPER, PENNYHEAD, SOLID

Solid stopper with closed bottom.

Part Number	Joint Size
CG-2098-01	14/20
CG-2098-02	19/22



CG-2098

CG-3000 STOPPER, PENNYHEAD, HOLLOW

Hollow penny head stopper with closed bottom.

Part Number	Joint Size
CG-3000-10	10/18
CG-3000-01	10/30
CG-3000-02	12/30
CG-3000-14	14/20

CG-3000-03	14/35
CG-3000-19	19/22
CG-3000-04	19/38
CG-3000-05	24/40

CG-3000-29	29/26
CG-3000-06	29/42
CG-3000-07	34/45
CG-3000-08	45/50
CG-3000-09	55/50



CG-3000

CG-3002 STOPPER, TEFLON, HOLLOW

Hollow Teflon Stopper.

Part Number	Joint Size
CG-3002-10	10/18
CG-3002-01	10/30
CG-3002-14	14/20

CG-3002-19	19/22
CG-3002-05	24/40
CG-3002-06	29/42
CG-3002-08	45/50



CG-3002

CG-3002-L STOPPER, EXTRACTION NUT, TEFLON

Teflon stopper has a Polypropylene extraction nut permitting easy removal of the stopper from the glass outer joint. The 14/20 and 19/22 are solid, while the larger sizes are hollow.

Part Number	Joint Size	Type
CG-3002-L-14	14/20	Solid
CG-3002-L-19	19/22	Solid
CG-3002-L-24	24/40	Hollow
CG-3002-L-29	29/42	Hollow
CG-3002-L-34	34/45	Hollow
CG-3002-L-45	45/50	Hollow



CG-3002-L

STOPPERS

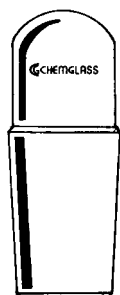

CG-3004

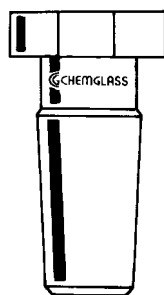

CG-3006

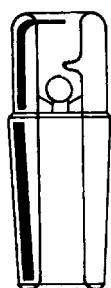

CG-3007

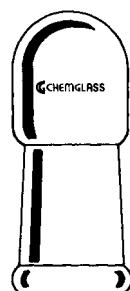

CG-3008

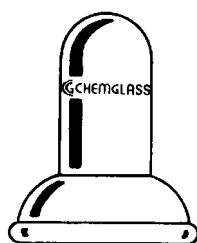

CG-3014

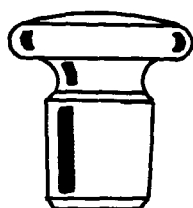

CG-3016

CG-3004 STOPPER, CYLINDRICAL, ECONOMY

For use in standard taper outer joints. Economy style with open bottom.

Part Number	Joint Size
CG-3004-05	24/40
CG-3004-06	29/42

CG-3006 STOPPER, HEX HEAD, HOLLOW

Hexagonal shaped head of hollow stopper prevents it from rolling off of the bench top. Flat surface will also permit stopper to be inverted and placed on end, thereby preventing possible contamination of ground surface.

Part Number	Joint Size
CG-3006-14	14/20
CG-3006-01	24/40

CG-3007 STOPPER, PRESSURE RELEASE, HOLLOW

Stopper has a 1/4" OD ceramic ball check valve contained within the hollow portion of the stopper. The valve remains closed until pressure from within the vessel builds up and pushes the ceramic ball from its seat.

Part Number	Joint Size
CG-3007-01	24/40
CG-3007-02	29/42

CG-3008 STOPPER, CAP STYLE

Cap style stopper for use with inner joints.

Part Number	Joint Size
CG-3008-14	14/20
CG-3008-19	19/22
CG-3008-05	24/40

CG-3014 STOPPER, SPHERICAL, CAP STYLE

Cap style stopper to be used with apparatus having a spherical ball joint. For clamp see CG-150.

Part Number	Joint Size
CG-3014-02	18
CG-3014-03	28
CG-3014-04	35

CG-3016 STOPPER, FLASK LENGTH, FLAT HEAD

Flat head design allows stopper to be inverted and placed on end, thereby preventing possible contamination of ground surface.

Part Number	Joint Size
CG-3016-01	13
CG-3016-02	16

CG-3018 STOPPER, PENNY HEAD, SOLID, FLASK LENGTH

Flask length penny head stopper. All sizes are solid with the exception of the #38 (CG-3018-08) which is hollow. **PLEASE NOTE: FOR POLYETHYLENE FLASK LENGTH STOPPERS, SEE CG-8740.**

Part Number	Joint Size
CG-3018-01	9
CG-3018-02	13
CG-3018-03	16
CG-3018-04	19
CG-3018-05	22
CG-3018-06	27
CG-3018-07	32
CG-3018-08	38

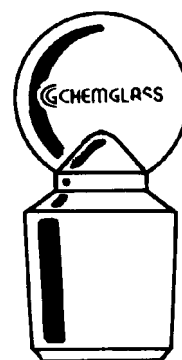

CG-3018

CG-3018-A STOPPER, PENNY HEAD, SOLID, FLASK LENGTH, LOW ACTINIC RED STAIN

Flask length solid penny head stopper with low actinic red stain.

Part Number	Joint Size
CG-3018-A-02	13
CG-3018-A-03	16
CG-3018-A-04	19
CG-3018-A-05	22
CG-3018-A-06	27



CG-3018-A

CG-3019 STOPPER, EXTRACTION NUT, FLASK LENGTH, TEFLON

Flask length Teflon stopper has a Polypropylene extraction nut permitting easy removal of the stopper from the flask. All sizes are solid.

Part Number	Joint Size
CG-3019-01	9
CG-3019-02	13
CG-3019-03	16
CG-3019-04	19
CG-3019-05	22
CG-3019-06	27
CG-3019-08	38



CG-3019

CG-3020 STOPPER, FLASK LENGTH, TEFLON

Flask length Teflon stopper.

Part Number	Joint Size
CG-3020-01	9
CG-3020-02	13
CG-3020-03	16
CG-3020-04	19
CG-3020-05	22
CG-3020-06	27
CG-3020-07	32
CG-3020-08	38



CG-3020

STOPPERS



CG-3020-A

CG-3020-A STOPPER, FLASK LENGTH, TEFLON, COLOR CODED

Flask length Teflon stopper with color coded handle.

Part Number	Joint Size	Handle Color	Type
CG-3020-A-01	9	Black	Solid
CG-3020-A-02	13	Orange	Solid
CG-3020-A-03	16	Blue	Solid
CG-3020-A-04	19	Green	Solid
CG-3020-A-05	22	Yellow	Solid
CG-3020-A-06	27	Red	Hollow
CG-3020-A-07	32	Gray	Hollow
CG-3020-A-08	38	Black	Hollow

CG-3021 STOPPER, POLYETHYLENE

Inexpensive tapered stopper provides for a tight, leakproof fit while the top ring permits the stopper to be easily removed. Stoppers are made of yellow Polyethylene. **SOLD 100/PKG.**

Part Number	Fits Standard Taper Joint Size
CG-3021-01	14/20
CG-3021-02	19/22
CG-3021-03	24/40
CG-3021-04	29/26-29/42



CG-3021

CG-3022 SEPTUM STOPPER, SLEEVE TYPE

Flanged type stoppers with a hollow plug and sleeve extension that folds down over the neck of a vessel, tubing, etc. The diaphragm can be punctured with a syringe needle, re-sealing after needle is withdrawn. Available in either RED or WHITE Rubber and sold in the package quantities listed below.

For Use With	Red Part Number	White Part Number	Pkg Qty
5mm OD NMR Tubes	CG-3022-09	CG-3022-20	100
8mm OD Standard Wall and 9mm OD Medium Wall Tubing	CG-3022-05	CG-3022-22	100
14/20-14/35 Outer Joints	CG-3022-06	CG-3022-24	100
	CG-3022-93	CG-3022-97	12
19/22-19/38 Outer Joints	CG-3022-07	CG-3022-26	100
	CG-3022-96	CG-3022-91	12
24/25-24/40 Outer Joints	CG-3022-08	CG-3022-28	100
	CG-3022-98	CG-3022-99	12
29/26-29/42 Outer Joints	CG-3022-10	CG-3022-30	100
	CG-3022-88	CG-3022-89	12



CG-3022

STOPPERS / SUBLIMATORS

CG-3024 SEPTUM STOPPER, SUBA-SEAL®

Suba-Seal® septa are a flanged stopper with a hollow plug and sleeve extension that folds down over the neck of the vessel. In addition to the pull over sleeve, Suba-Seal® stoppers have a series of annular serrations on the plug portion of the septa. Each of these serrations depress along the inner wall of the glass vessel to form an extremely effective air-tight seal. Stoppers are made from natural red rubber and sold in the package quantities listed below.

Part Number	Fits Standard Taper Joint Size	Fits Tubing ID (mm)	Pkg Qty
CG-3024-01	14/20-14/35	12.5	100
CG-3024-03	19/22-19/38	17.5	100
CG-3024-05	24/25-24/40	20.5	100
CG-3024-07	29/26-29/42	25.5	100
CG-3024-09	29/26-29/42	25.5	50



CG-3024

CG-3030 SUBLIMER, MICRO

Micro scale sublimer can be used with quantities as small as 0.5 grams. The sublimer has a capacity of 3mL between the lower portion of the cold finger and the interior bottom of the flask. With 24/25 standard taper joints to connect the flask and cold finger condenser.

Complete Sublimer:

Part Number	Approx. Height x Width (mm)
CG-3030-01	160 x 85

Replacement Components:

Part Number	Description
CG-3030-02	Lower Flask Only
CG-3030-03	Cold Finger Condenser Only

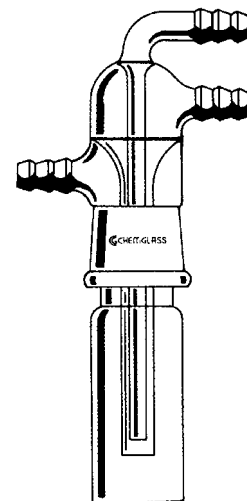

CG-3030

CG-3032 SUBLIMATION ADAPTER

Adapter permits sublimation directly in any reaction vessel having an standard taper outer joint. Simply remove condenser or other apparatus from joint, insert adapter and begin. Adapter has two components, the cold finger condenser and vacuum adapter. Adapter has a #18 Chem-Thread to allow for the vertical positioning of the cold finger in flasks from 250 to 1000mL. Vacuum is controlled via a 2mm Teflon stopcock. Adapter joint sizes are medium length, but can be used in full length joints.

Complete Adapter:

Part Number	Joint Size
CG-3032-01	24/25
CG-3032-02	29/26

Replacement Components:

Part Number	Description
CG-3032-03	24/25 Vacuum Adapter Only
CG-3032-04	29/26 Vacuum Adapter Only
CG-3032-05	Cold Finger Condenser Only
CG-305-208	#208 Viton O-Rings, 6/Pkg
CG-352-04	#18 Compression Cap
CG-424-77	2mm Teflon Plug

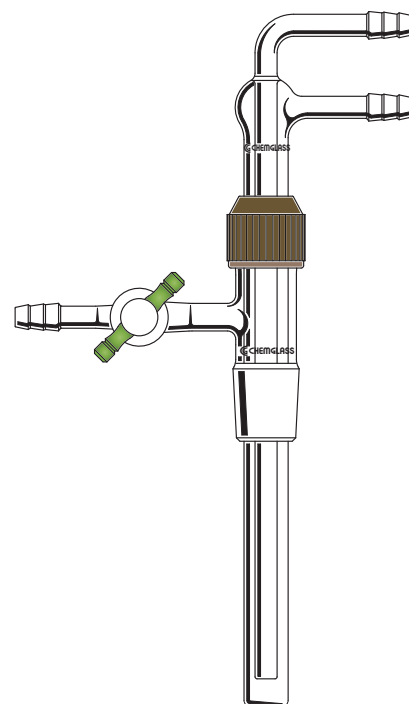

CG-3032

Visit Our Web Site: www.gpelimited.co.uk